

Visualisation des points jaunes = position indéxée.

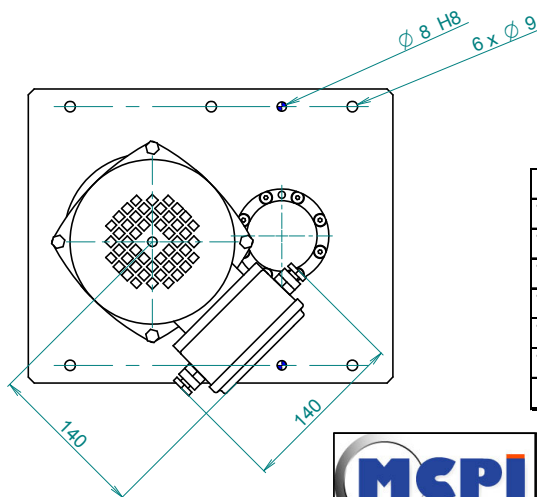

Nomenclatures	
T35/V2 PAR+PER	
T35/V3-	-DIV -
T35 CFC 1 (360°) ou CFC 2 (180°)	
T35 OP CF	
T35 OP PM	
T35/V2 AL154	
L154-	-

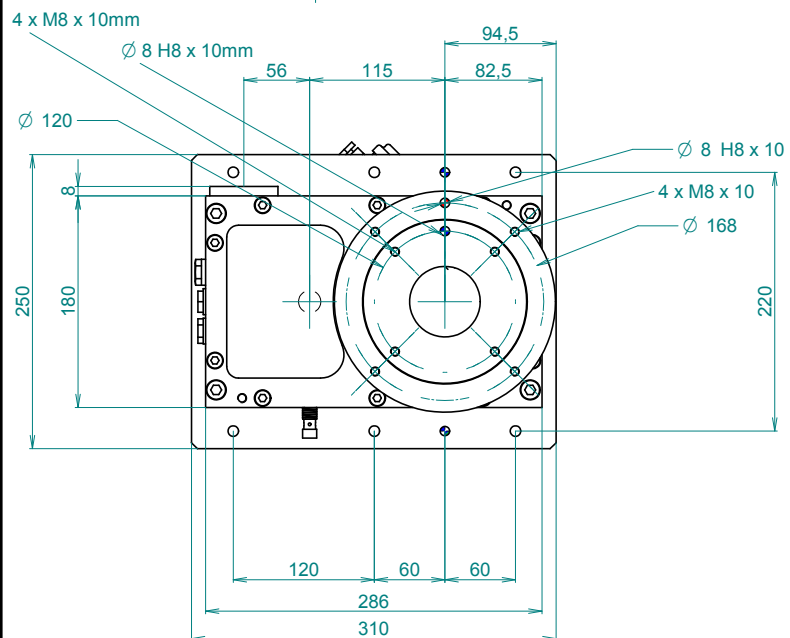
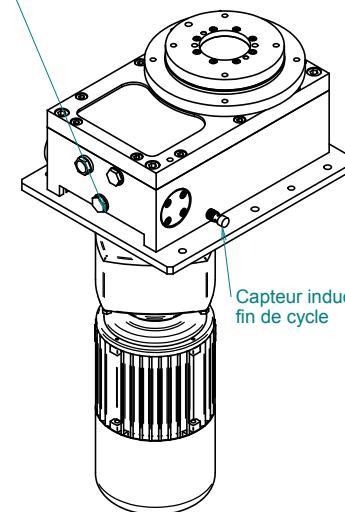

40, Route de cotfa BP 1013
F-74 966 MEYTHET CEDEX
tel 04-50-33-90-20
fax 04-55-10-12-96
Email mcpimail@mcpi.fr

FICHER : ST350-71-21-M10-FC2-PF1-A2L154-OCF1.asm

GRUPE : ST35 PA

auteur : V MORARD

Date : 17/06/2005

Produit : ST35 PA

Ind : E

N°: ST350-71-21-M10-FC2-PF1-A2L154-OCF1