

VUE DE DESSOUS POUR FIXATION

Nomenclatures	
T55 PA PE (version parallèle ou perpendiculaire)	
T55- DIV- -	
T50-CFC-1C (360°) ou 2C (180°)	
T55 M10	
T50/V2 AD.MOT.L500	
A500- - -	
ST55-01-03-45 ou ST55-01-03-46	Suivant div

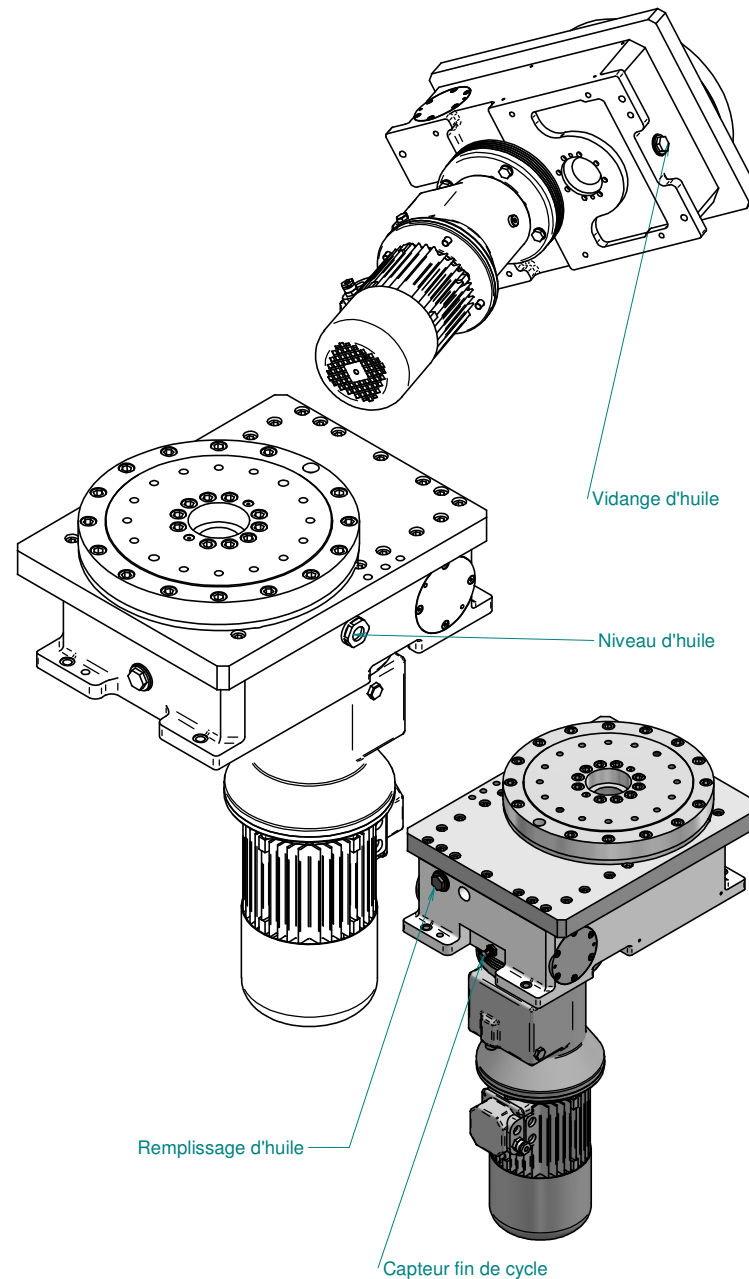
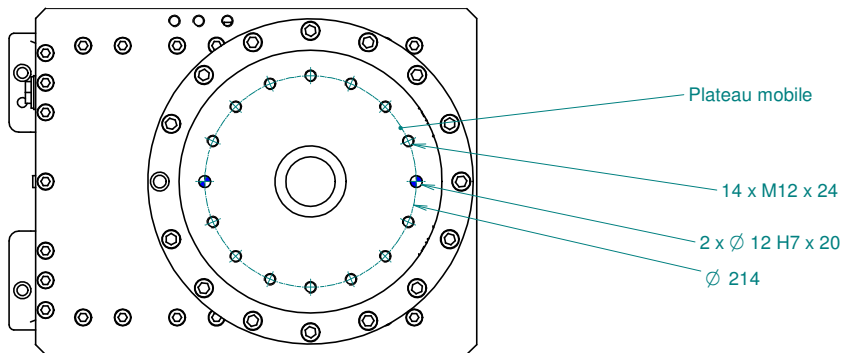

	40, Route de cotfa BP 1013 F-74 966 MEYTHET CEDEX tel 04-50-33-90-20 fax 04-55-10-12-96 Email mcpimail@mcp.fr	FICHER : ST550-80-N1-M10-FC2-PF0-A5A500-OCF0.asm	
		GROUPE : T55 PA auteur : V.MORARD	Date : 04/07/2005
Produit : T55 PA came fin de cycle inductif			Ind : F
N°: ST550-80-N1-M10-FC2-PF0-A5A500-OCF0			